

INSTRUCTION MANUAL

DMF-42

**Pedestal Mill Drill - Geared & Tilting
Head (240V)**

(X) 370mm (Y) 175mm (Z) 780mm

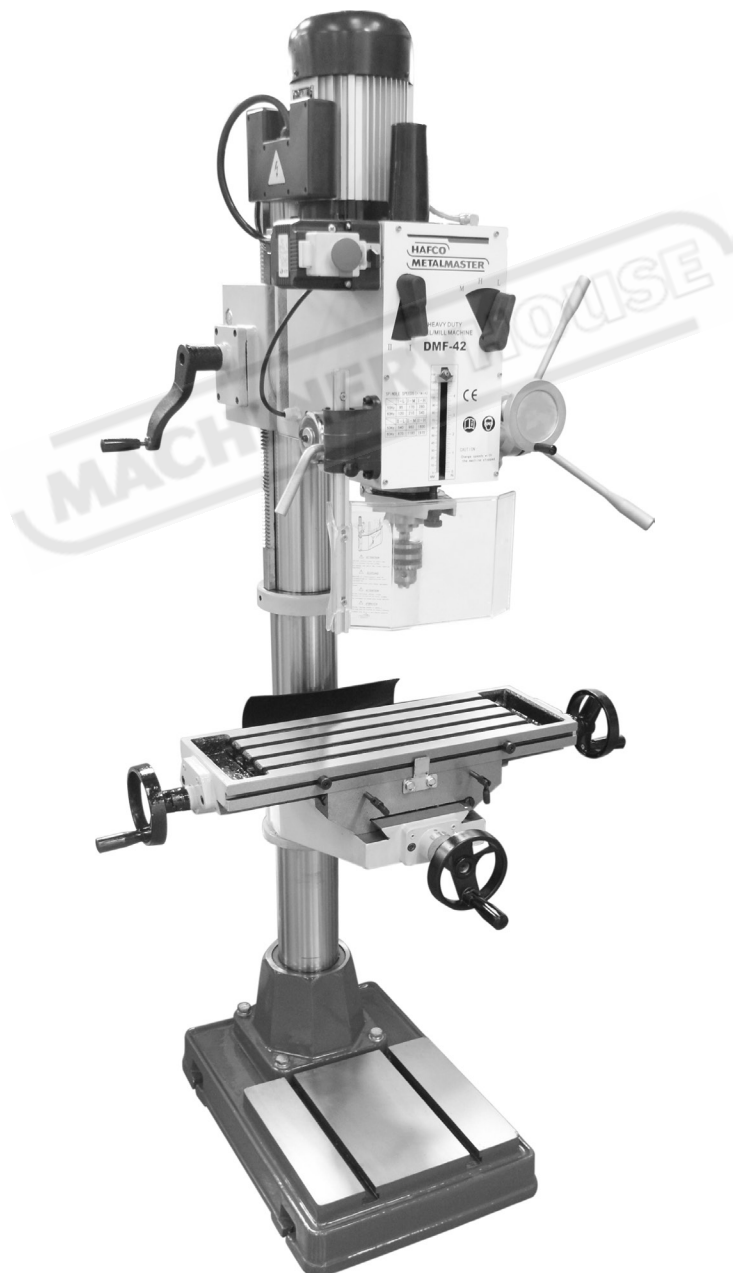

D181A

PLANT SAFETY PROGRAM NEW MACHINERY HAZARD IDENTIFICATION, ASSESSMENT & CONTROL

Drilling Machine

Developed in Co-operation Between A.W.I.S.A and Australia Chamber of Manufactures
This program is based upon the Australian Worksafe Standard for Plant(NOHSC:1010-1994)



Item No.	Hazard Identification	Hazard Assessment	Risk Control Strategies <small>(Recommended for Purchase / Buyer / User)</small>
A	ENTANGLEMENT	HIGH	Eliminate, avoid loose clothing / Long hair etc.
B	CRUSHING	LOW	Secure & support work material on drill table.
C	CUTTING, STABBING, PUNCTURING.	MEDIUM	Isolate power to machine prior to any checks or maintenance being carried out.
D	SHEARING	MEDIUM	Do not adjust or clean until the machine has fully stopped. Isolate power to machine when changing speeds or maintenance is being carried out.
F	STRIKING	MEDIUM	Make sure all guards are secured shut when machine is on. Ensure workpieces are tightly secured on machine. Wear safety glasses.
H	ELECTRICAL	MEDIUM	For Radial Arm Drills ensure that arm is locked before drilling. Ensure correct spindle direction when drilling. All electrical enclosures should only be opened with a tool that is not to be kept with the machine. Never clean or dust machine when power is on. Machine should be installed & checked by a Licensed Electrician.
M	HIGH TEMPERATURE	LOW	Wear appropriate protective clothing to prevent hot swarf.
O	OTHER HAZARDS, NOISE.	LOW	Wear hearing protection as required.
Plant Safety Program to be read in conjunction with manufactures instructions			



www.machineryhouse.com.au



www.machineryhouse.co.nz

Authorised and signed by: 
Safety officer: 
Manager: 

Revised Date: Aug-08

WARNING

Drilling Machine Safety Instructions

Machinery House
requires you to read this entire Manual before using this machine.

- 1. Maintenance.** Make sure the Drill is turned off and disconnect from the main power supply and make sure all moving parts have come to a complete stop before any inspection, adjustment or maintenance is carried out.
- 2. Drill Condition.** Drill must be maintained for a proper working condition. Never operate a Drill that has damaged or worn parts. Scheduled routine maintenance should be performed on a scheduled basis.
- 3. Leaving a Drill Unattended.** Always turn the Drill off and make sure all moving parts have come to a complete stop before leaving the Drill. Do not leave Drill running unattended for any reason.
- 4. Avoiding Entanglement.** Remove loose clothing, belts, or jewelry items. Never wear gloves while machine is in operation. Tie up long hair and use the correct hair nets to avoid any entanglement with the Drill spindle or moving parts.
- 5. Chuck key & wrench safety.** Always remove chuck keys, wrenches and any service tools immediately after use. Chuck keys left in the chuck can cause serious injury.
- 6. Understand the machines controls.** Make sure you understand the use and operation of all controls.
- 7. Drill bit selection.** Always use the correct Drill bit for the job you are Drilling. Make sure you use the correct shank drill bit for your drilling machine.
- 8. Secure the Drill Bit.** Properly tighten and securely lock the drill bit in the chuck.
- 9. Cutting Tool Inspection.** Inspect Drill for sharpness, chips, or cracks before use. Replace any cutting tools immediately if dull, chipped or cracked. Handle new cutting tools with care. Cutting edges are very sharp and can cause lacerations.
- 10. Reversing the spindle.** Make sure the spindle has come to a complete stop before changing the direction of the spindle.
- 11. Stopping the spindle.** Do not slow or stop the spindle by using your hand.
- 12. Speed selection.** Select the appropriate speed for the type of work, material, and tool bit. Allow the Drill to reach full speed before beginning a cut.
- 13. Changing Belts for speed selection.** Always allow the machine to come to a complete stop and turn power off before changing belts. Not turning power off when changing belts can cause serious injury.
- 14. Clearing chips.** Always use a brush to clear chips. Never clear chips when the drill is running.
- 15. Power outage.** In the event of a power failure during use of the drill, turn off all switches to avoid possible sudden start up once power is restored.
- 16. Clean work area.** Keep the area around the drill clean from oil, tools, chips.
- 17. Surface/workpiece area.** Before turning the drill on, make sure the table is clear of any objects (tools, scraps, off-cuts etc.) Do not drill material that does not have a flat surface, unless a suitable support is used.
- 18. Table Lock.** Make sure the table is tightened before starting the drill.
- 19. For - Radial Drill Arm Lock.** Make sure the arm is locked before leaving or starting a radial arm drill. An unlocked radial drill arm can swing and cause serious injury.
- 20. Drilling Sheet metal.** All sheet metal should be clamped to the table before drilling.
- 21. Mounting workpieces.** Use clamps or vices to secure workpiece before drilling. Position work so you avoid drilling into table.
- 22. Guarding.** Do not operate the drill when chuck guard is removed.
- 23. Eye and hand protection.** A face shield with safety glasses is recommended. Always keep hands and fingers away from the drill bit. Never hold a workpiece in your hand while drilling. Do not wear gloves while operating the drill.
- 24. Drill operation.** Never start the drill with the drill bit pressed against the workpiece. Feed the drill evenly into the workpiece. Back the drill out of deep holes. Turn the machine off and clear chips and scrap pieces with a brush. Turn power off, remove drill bit, and clean the table before leaving the machine.
- 25. Call for help.** If at any time you experience difficulties, stop the machine and call your nearest branch service department for help.



General Machinery Safety Instructions

Machinery House
requires you to read this entire Manual before using this machine.

1. **Read the entire Manual before starting machinery.** Machinery may cause serious injury if not correctly used.
2. **Always use correct hearing protection when operating machinery.** Machinery noise may cause permanent hearing damage.
3. **Machinery must never be used when tired, or under the influence of drugs or alcohol.** When running machinery you must be alert at all times.
4. **Wear correct Clothing.** At all times remove all loose clothing, necklaces, rings, jewelry, etc. Long hair must be contained in a hair net. Non-slip protective footwear must be worn.
5. **Always wear correct respirators around fumes or dust when operating machinery.** Machinery fumes & dust can cause serious respiratory illness. Dust extractors must be used where applicable.
6. **Always wear correct safety glasses.** When machining you must use the correct eye protection to prevent injuring your eyes.
7. **Keep work clean and make sure you have good lighting.** Cluttered and dark shadows may cause accidents.
8. **Personnel must be properly trained or well supervised when operating machinery.** Make sure you have clear and safe understanding of the machine you are operating.
9. **Keep children and visitors away.** Make sure children and visitors are at a safe distance for your work area.
10. **Keep your workshop childproof.** Use padlocks, Turn off master power switches and remove start switch keys.
11. **Never leave machine unattended.** Turn power off and wait till machine has come to a complete stop before leaving the machine unattended.
12. **Make a safe working environment.** Do not use machine in a damp, wet area, or where flammable or noxious fumes may exist.
13. **Disconnect main power before service machine.** Make sure power switch is in the off position before re-connecting.
14. **Use correct amperage extension cords.** Undersized extension cords overheat and lose power. Replace extension cords if they become damaged.
15. **Keep machine well maintained.** Keep blades sharp and clean for best and safest performance. Follow instructions when lubricating and changing accessories.
16. **Keep machine well guarded.** Make sure guards on machine are in place and are all working correctly.
17. **Do not overreach.** Keep proper footing and balance at all times.
18. **Secure workpiece.** Use clamps or a vice to hold the workpiece where practical. Keeping the workpiece secure will free up your hand to operate the machine and will protect hand from injury.
19. **Check machine over before operating.** Check machine for damaged parts, loose bolts, Keys and wrenches left on machine and any other conditions that may effect the machines operation. Repair and replace damaged parts.
20. **Use recommended accessories.** Refer to instruction manual or ask correct service officer when using accessories. The use of improper accessories may cause the risk of injury.
21. **Do not force machinery.** Work at the speed and capacity at which the machine or accessory was designed.
22. **Use correct lifting practice.** Always use the correct lifting methods when using machinery. Incorrect lifting methods can cause serious injury.
23. **Lock mobile bases.** Make sure any mobile bases are locked before using machine.
24. **Allergic reactions.** Certain metal shavings and cutting fluids may cause an allergic reaction in people and animals, especially when cutting as the fumes can be inhaled. Make sure you know what type of metal and cutting fluid you will be exposed to and how to avoid contamination.
25. **Call for help.** If at any time you experience difficulties, stop the machine and call you nearest branch service department for help.

WARNING: FAILURE TO FOLLOW THESE RULES MAY RESULT IN SERIOUS PERSONAL INJURY

As with all machine there are certain hazards involved with operation and use of the machine. Using the machine with respect and caution will considerably reduce the possibility of personal injury. However, if normal safety precautions are overlooked or ignored, personal injury to the operator may result.

This machine was designed for certain applications only. We strongly recommend that this machine NOT be modified and /or used for any application other than for which it was designed. If you have any questions relative to its application DO NOT use the machine until you have had detail instruction from dealer.

SAFETY RULES FOR ALL TOOLS

1. For your own safety, read instruction manual before operating the tool. Learn the tool's application and limitations as well as the specific hazards peculiar to it.
2. Keep guards in place and in working order.
3. Ground all tools. If tool is equipped with three-prong plug, it should be plugged into a three-hole electrical receptacle. If an adapter is used to accommodate a two-prong receptacle, the adapter lug must be attached to a known ground. Never remove the third prong.
4. Remove adjusting keys and wrenches. Form habit of checking to see that keys and adjusting wrenches are removed from tool before turning it "on".
5. Keep work area clean. Cluttered areas and benches invite accidents.
6. Don't use in dangerous environment. Don't use power tools in damp or wet locations, or expose them to rain. Keep work area well-lighted.
7. Keep children and visitors away. All children and visitors should be kept a safe distance from work area.
8. Make workshop childproof with padlocks, master switches, or by removing starter keys.
9. Don't force tool. It will do the job better and be safer at the rate for which it was designed.
10. Use right tool. Don't force tool or attachment to do a job for which it was designed.
11. Wear proper apparel. No loose clothing, gloves, neckties, rings, bracelets, or other jewelry to get caught in moving parts. Nonslip foot wear is recommended. Wear protective hair covering to contain long hair.
12. Always wear eye protection. Refer to standard for appropriate recommendations. Also use face if dust mask if cutting operation is dusty.
13. Secure work. Use clamps or a vise to hold work when practical. It's safer than using your hand and frees both hands to operate tool.
14. Don't overreach. Keep proper footing and balance at all times.

15. Maintain tools in top condition. Keep tools sharp and clean for best and safest performance. Follow instructions for lubricating and changing accessories.
16. Disconnect tools before servicing and when changing accessories such as blades, bits, cutters, etc.
17. Use recommended accessories. Consult the owner's manual for recommended accessories. The use of improper accessories may cause hazards.
18. Avoid accidental starting. Make sure switch is in "OFF" position before plugging in power cord.
19. Never stand on tool. Serious injury could occur if the tool is tipped or if the cutting tool is accidentally contacted.
20. Check damaged parts. Before further use of the tool, a guard or other part that is damaged should be carefully checked to ensure that it will operate properly and perform its intended function check for alignment of moving parts, breakage of parts, mounting, and any other conditions that may affect its operation. A guard or other part that is damaged should be properly repaired or replaced.
21. Never leave tool running unattended. Turn power off. Don't leave tool until it comes to a complete stop.
22. Drugs, alcohol, medication. Do not operate tool while under the influence of drug, alcohol or any medication.
23. Make sure tool is disconnected from power supply while motor is being mounted, connected or reconnected.
24. Please equip with overload protective device before operate the machine.
25. By testing, the lifting equipment is able to lift tri-weight of the machine.

ADDITIONAL SAFETY RULES FOR MILL/DRILL

1. Be sure drill bit or cutting tool is securely locked in the chuck.
2. Be sure chuck key is removed from the chuck before turning on power.
3. Adjust the table or depth stop to avoid drilling into the table.
4. Shut off the power, remove the drill bit or cutting tool, and clean the table before leaving the machine.
5. Caution. When practical, use clamps or a vise to secure workpiece to keep the workpiece from rotating with the drill bit or cutting tool.
6. Warning: For you own safety- Don't wear gloves when operating a mill/drill.
7. The protection guade shall be prevent to crushing, cutting and entanglement hazard. The guade equip with interlock switch, when it at the correction station, the machine can be started.
8. Be sure all use PPE products (e.f: glasses gloves and shoes) are in accordance with European relevant safety rules.
9. Be sure that 500lux shall be ensured for working.

SPECIFICATIONS:

MODEL	ZX-32HC	ZX-32HS	DMF-42	ZX-45HC	Z5040	Z5045
Max. drilling capacity (mm) (in)	31.5 (1-1/4")			45 (1-3/4")	31.5 (1-1/4")	45 (1-3/4")
Face mill capacity (mm) (in)	80 (3-1/7")	—	80 (3-1/7")		—	—
End mill capacity (mm) (in)	22 (7/8")	—	22 (7/8")	28 (1-1/10")	—	—
Swing (mm) (in)	405 (16")		505 (19-7/8")		545 (21-2/5")	
Max. distance spindle nose to table (mm) (in)	785 (30-9/10")	835 (32-7/8")	780 (30-3/4")	760 (29-9/10")	830 (32-2/3")	815 (32-1/12")
Max. distance spindle nose to base (mm) (in)	1275 (50-1/5")		1270 (50")	1255 (49-2/5")	1270 (50")	1255 (49-2/5")
Spindle taper	MT. 3 OR R8			MT. 4 OR R8	MT. 3 OR R8	MT. 4 OR R8
Spindle stroke (mm) (in)	130 (5-1/9")		120 (4-2/3")			
Spindle speed (r/min)	50Hz	100, 160, 190, 240, 310, 365, 660, 885, 1020, 1260, 1510, 2150		95, 170, 190, 280, 340, 540, 560, 960, 1080, 1600, 1920, 3200		
	60Hz	120, 195, 230, 285, 375, 440, 790, 1065, 1220, 1515, 1810, 2580		120, 210, 340, 670, 1180, 1970		
Head swivel				360°		
Head tilt left right				180°		
Diameter of column (mm) (in)	∅115 (4-1/2")					
Working surface of table (mm) (in)	585x190 (23"x7-1/2") (cross)	540x470 (21-1/4"x18-1/2") (square)	585x190 (23"x7-1/2") (cross)		540x470 (21-1/4"x18-1/2") (square)	
Travel of table (mm) (in)	370x180 (14-1/2"x7")	515 (20-1/4")	370x180 (14-1/2"x7")		515 (20-1/4")	
Overall height (LxWxH) (cm) (in)	95x99x177 (37-2/5"x39" x69-3/4")	59x95x177 (23-1/4"x37-2/5" x69-3/4")	95x77x177 (37-2/5"x30-1/3"x69-3/4")		62x72x177 (24-2/5"x28-1/2"x69-3/4")	
Gross/Net weight (kg)	345/305		330/290		350/310	

ACCESSORIES:

∅16mm (5/8") chuck with key and tapered bar

∅80mm (3-1/7") cutter with tapered bar

* Tapered adapter sleeve MT. 3-MT. 2

MT. 4-MT. 3 (only for MT. 4 spindle)

Slotted tapered sleeve (only for MT. 4 spindle)

∅24mm (17/18") lock wrench (only for STEP PULLEY DUTY)

∅24mm (17/18") double open and spanner (only for GEARED DUTY)

Inner hex key 4mm (1/7"), 5mm (1/5"), 6mm (1/4") one each

* Wedge

Arbor rod

Handle of spindle head

* Note: 1. when R8 is selected, there is no tapered sleeve and no wedge.

2. when square working table is selected, there is only for "#".

SPECIFICATIONS:

MODEL	ZX-32HCL	ZX-32HSL	ZX-40HCL	ZX-45HCL	Z5040L	Z5045L
Max. drilling capacity (mm) (in)	31.5 (1-1/4")			45 (1-3/4")	31.5 (1-1/4")	45 (1-3/4")
Face mill capacity (mm) (in)	80 (3-1/7")	—	80 (3-1/7")		—	—
End mill capacity (mm) (in)	22 (7/8")	—	22 (7/8")	28 (1-1/10")	—	—
Swing (mm) (in)	405 (16")		505 (19-7/8")		545 (21-2/5")	
Max. distance spindle nose to table (mm) (in)	785 (30-9/10")	835 (32-7/8")	780 (30-3/4")	760 (29-9/10")	830 (32-2/3")	815 (32-1/12")
Max. distance spindle nose to base (mm) (in)	1305 (51-1/3")		1300 (51-1/6")	1285 (50-1/2")	1300 (51-1/6")	1285 (50-1/2")
Spindle taper	MT. 3 OR R8			MT. 4 OR R8	MT. 3 OR R8	MT. 4 OR R8
Spindle stroke (mm) (in)	130 (5-1/9")		120 (4-2/3")			
Spindle speed (r/min)	50Hz	100, 160, 190, 240, 310, 365, 660, 885, 1020, 1260, 1510, 2150		95, 170, 280, 540, 960, 1600		
	60Hz	120, 195, 230, 285, 375, 440, 790, 1065, 1220, 1515, 1810, 2580		120, 210, 340, 670, 1180, 1970		
Head swivel	360°					
Head tilt left right	180°					
Diameter of column (mm) (in)	Ø115 (4-1/2")					
Working surface of table (mm) (in)	585x190 (23"x7-1/2") (cross)	540x470 (21-1/4"x18-1/2") (square)	585x190 (23"x7-1/2") (cross)		540x470 (21-1/4"x18-1/2") (square)	
Travel of table (mm) (in)	370x180 (14-1/2"x7")	515 (20-1/4')	370x180 (14-1/2"x7")		515 (20-1/4")	
Overall height (LxWxH) (cm) (in)	95x99x181 (37-2/5"x39"x71-2/7")	59x95x177 (23-1/4"x37-2/5"x71-2/7")	95x82x181 (37-2/5"x32-1/3"x71-2/7")		62x72x181 (24-2/5"x28-1/2"x71-2/7")	
Gross/Net weight (kg)	350/310	335/295	355/315		340/300	

ACCESSORIES:

Ø16mm (5/8") chuck with key and tapered bar

Ø80mm (3-1/7") cutter with tapered bar

* Tapered adapter sleeve MT. 3-MT. 2

MT. 4-MT. 3 (only for MT. 4 spindle)

Slotted tapered sleeve (only for MT. 4 spindle)

Ø24mm (17/18") lock wrench (only for STEP PULLEY DUTY)

Ø24mm (17/18") double open and spanner (only for GEARED DUTY)

Inner hex key 4mm (1/7"), 5mm (1/5"), 6mm (1/4") one each

* Wedge

Arbor rod

Handle of spindle head

* Note: 1. when R8 is selected, there is no tapered sleeve and no wedge.

2. when square working table is selected, there is only for "#".

SPECIFICATIONS:

MODEL		ZX-32HCD	ZX-40HCD	ZX-45HCD
Max. drilling capacity (mm) (in)		31.5 (1-1/4")		45 (1-3/4")
Face mill capacity (mm) (in)		80 (3-1/7")		80 (3-1/7")
End mill capacity (mm) (in)		22 (7/8")		28 (1-1/10")
Swing (mm) (in)		405 (16")	505 (19-7/8")	
Max. distance spindle nose to table (mm) (in)		780 (30-3/4")	775 (30-1/2")	760 (29-9/10")
Max. distance spindle nose to base (mm) (in)		1275 (50-1/5")	1270 (50")	1255 (49-2/5")
Spindle taper		MT. 3 OR R8	MT. 3 OR R8	MT. 4 OR R8
Spindle stroke (mm) (in)		130 (5-1/9")	120 (4-2/3")	
Spindle speed (r/min)	50Hz	100, 160, 190, 240, 310, 365, 660, 885, 1020, 1260, 1510, 2150	95, 170, 280, 540, 960, 1600	
	60Hz	120, 195, 230, 285, 375, 440, 790, 1065, 1220, 1515, 1810, 2580	120, 210, 340, 670, 1180, 1970	
Head swivel		360°		
Head tilt left right		180°		
Diameter of column (mm) (in)		Ø115 (4-1/2")		
Working surface of table (mm) (in)		730x210 (28-3/4"x8-1/4") (cross)		
Travel of table (mm) (in)		500x190x505 (19-2/3"x7-2/5"x19-7/8")		
Overall height (LxWxH) (cm) (in)		109x102x177 (42-9/10"x40-1/6"x69-3/4")	109x80x177 (42-9/10"x31-1/2"x69-3/4")	
Gross/Net weight (kg)		350/310	355/315	

ACCESSORIES:

Ø16mm (5/8") chuck with key and tapered bar

Ø80mm (3-1/7") cutter with tapered bar

* Tapered adapter sleeve MT.3-MT.2

MT.4-MT.3 (only for MT.4 spindle)

Slotted tapered sleeve (only for MT.4 spindle)

Ø24mm (17/18") lock wrench (only for STEP PULLEY DUTY)

Ø24mm (17/18") double open and spanner (only for GEARED DUTY)

Inner hex key 4mm (1/7"), 5mm (1/5"), 6mm (1/4") one each

* Wedge

Arbor rod

Handle of spindle head

Note: 1. when R8 is selected, there is no tapered sleeve and no wedge.

SPECIFICATIONS:

MODEL	ZX-32HCDL	ZX-40HCDL	ZX-45HCDL
Max. drilling capacity (mm) (in)	31.5 (1-1/4")		45 (1-3/4")
Face mill capacity (mm) (in)	80 (3-1/7")		80 (3-1/7")
End mill capacity (mm) (in)	22 (7/8")		28 (1-1/10")
Swing (mm) (in)	405 (16")	505 (19-7/8")	
Max. distance spindle nose to table (mm) (in)	780 (30-3/4")	775 (30-1/2")	760 (29-9/10")
Max. distance spindle nose to base (mm) (in)	1305 (51-1/3")	1300 (51-1/6")	1285 (50-1/2")
Spindle taper	MT. 3 OR R8	MT. 3 OR R8	MT. 4 OR R8
Spindle stroke (mm) (in)	130 (5-1/9")	120 (4-2/3")	
Spindle speed (r/min)	50Hz	100, 160, 190, 240, 310, 365, 660, 885, 1020, 1260, 1510, 2150	95, 170, 280, 540, 960, 1600
	60Hz	120, 195, 230, 285, 375, 440, 790, 1065, 1220, 1515, 1810, 2580	120, 210, 340, 670, 1180, 1970
Head swivel	360°		
Head tilt left right	180°		
Diameter of column (mm) (in)	Ø115 (4-1/2")		
Working surface of table (mm) (in)	730x210 (28-3/4"x8-1/4") (cross)		
Travel of table (mm) (in)	500x190x505 (19-2/3"x7-2/5"x19-7/8")		
Overall height (LxWxH) (cm) (in)	109x102x181 (42-9/10"x40-1/6"x71-2/7")	109x85x181 (42-9/10"x33-1/3"x71-2/7")	
Gross/Net weight (kg)	355/315		360/320

ACCESSORIES:

Ø16mm (5/8") chuck with key and tapered bar

Ø80mm (3-1/7") cutter with tapered bar

* Tapered adapter sleeve MT. 3-MT. 2

MT. 4-MT. 3 (only for MT. 4 spindle)

Slotted tapered sleeve (only for MT. 4 spindle)

Ø24mm (17/18") lock wrench (only for STEP PULLEY DUTY)

Ø24mm (17/18") double open and spanner (only for GEARED DUTY)

Inner hex key 4mm (1/7"), 5mm (1/5"), 6mm (1/4") one each

* Wedge

Arbor rod

Handle of spindle head

Note: 1. when R8 is selected, there is no tapered sleeve and no wedge.

MAIN INSTRUMENT

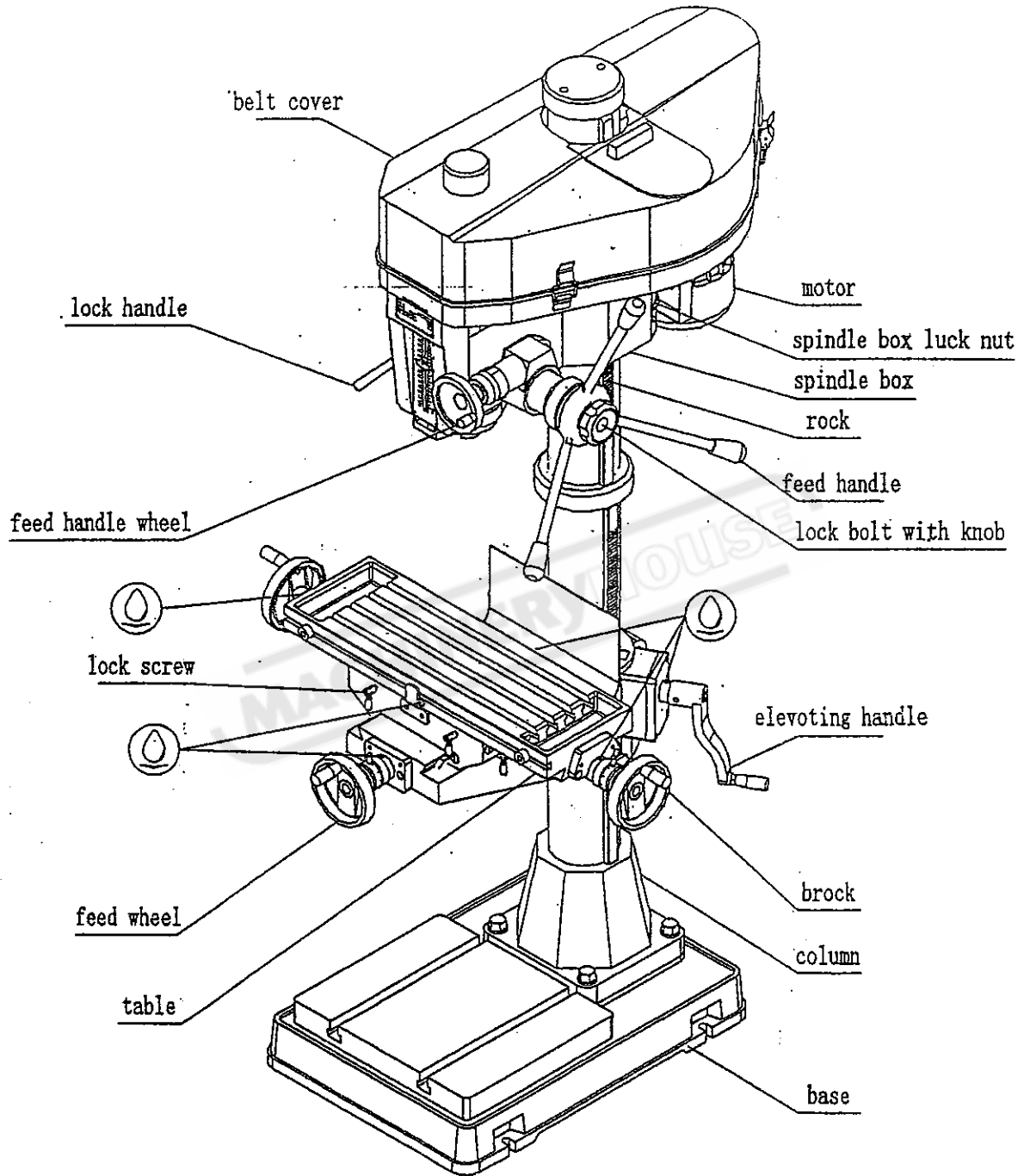

MAIN INSTRUMENT

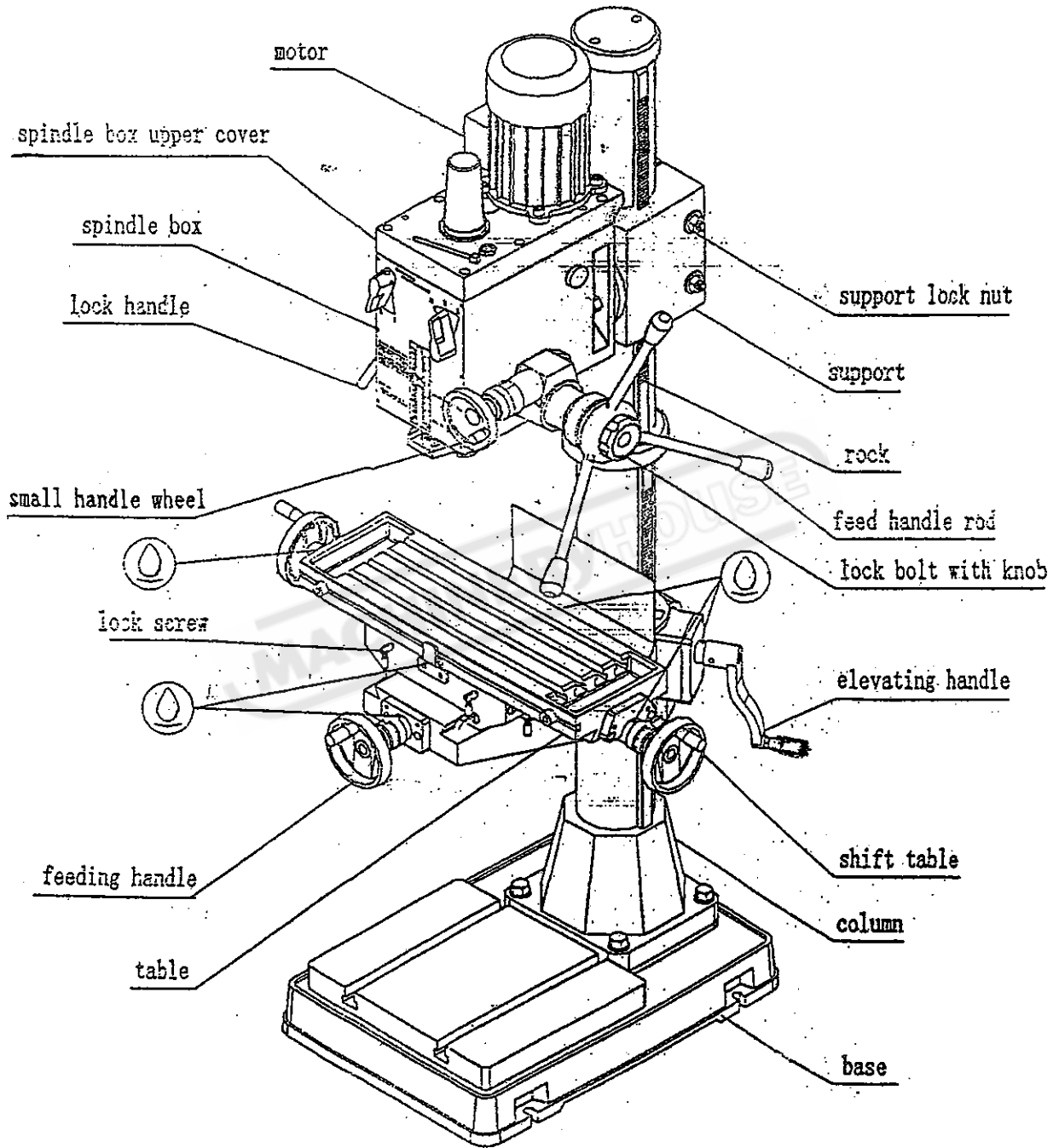

MAIN INSTRUMENT

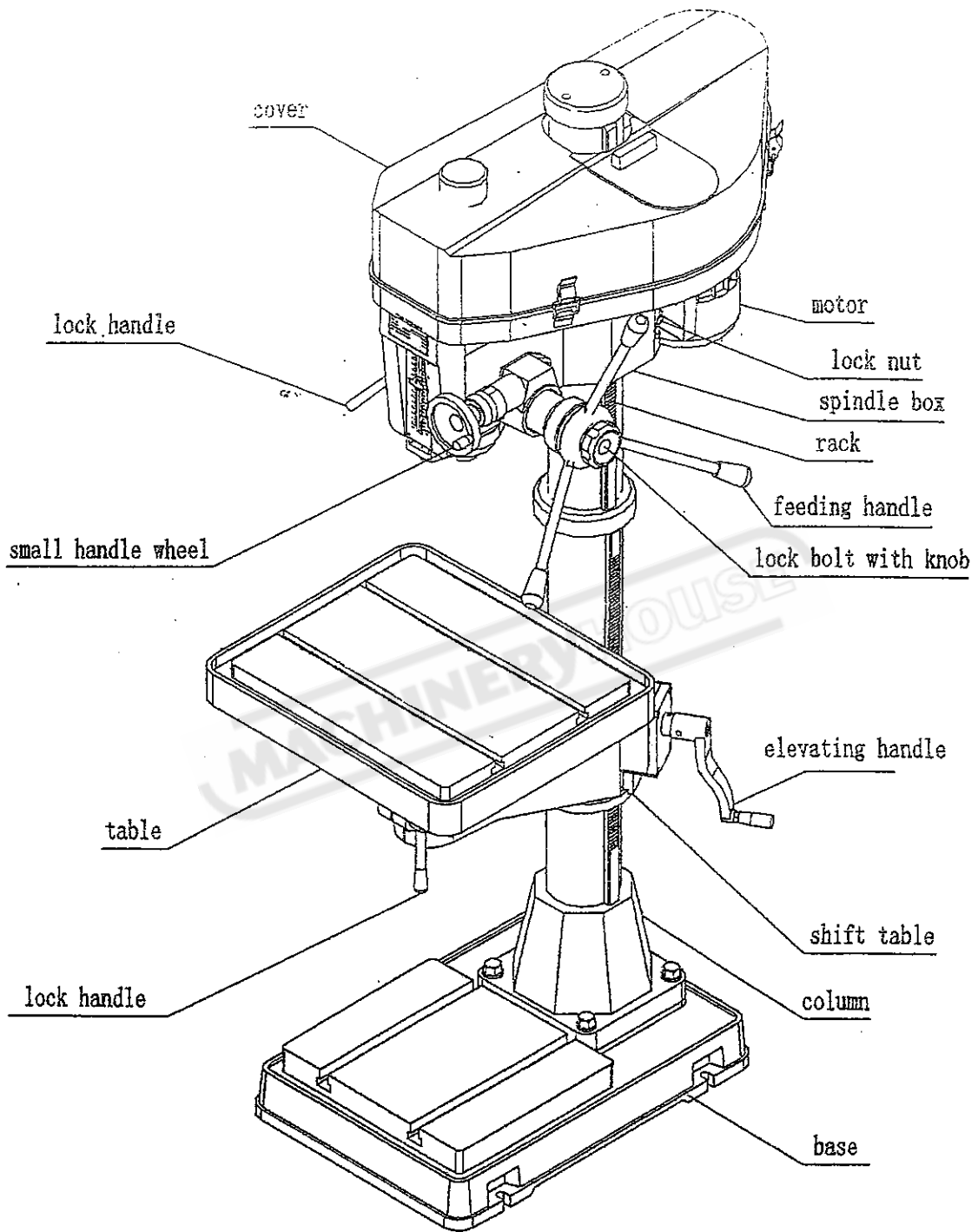

MAIN INSTRUMENT

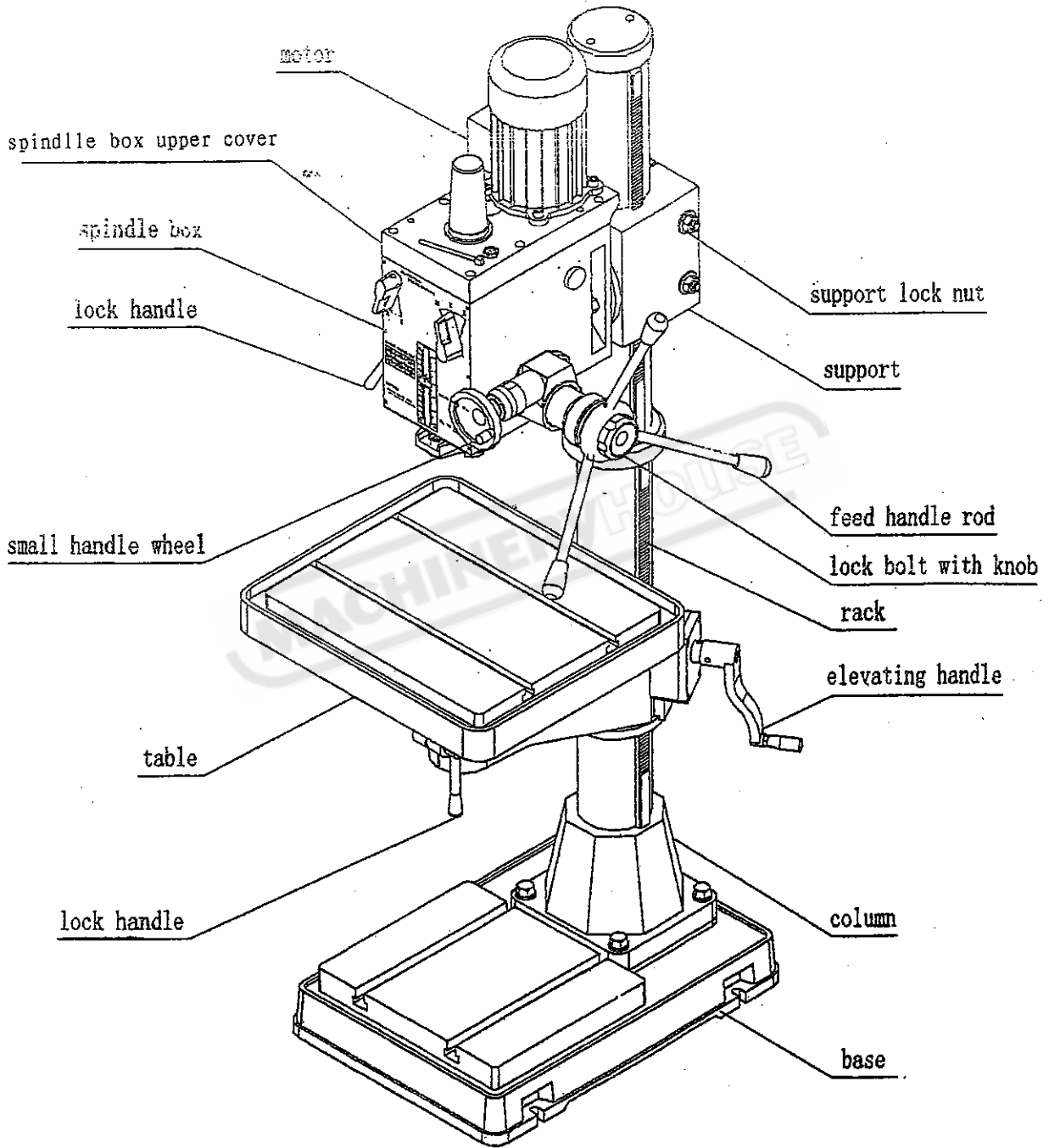

CLEANING

- 1) Your machine has been coated with a heavy grease to protect it in shipment. This coating should be completely removed before operating the machine. Commercial degreaser, kerosene or similar solvent may be used to remove the grease from the machine, but avoid getting solvent on belts or other rubber parts.
- 2) After cleaning, coat all bright work with a light lubrication. Lubricate all points with a medium consistency machine oil.

Lubrication

FOR STEP PULLEY: Lubrication points as shown in arrows

FOR GEARED HEAD:

All ball bearings in your mill/drill are sealed for life, requiring no lubrication. Points requiring lubrication are:

- 1) Internal spline drive assembly. Keep this area well lubricated with a good grade non-hardening grease. Insert grease in the hole at the top of spindle pulley spline driver. lube twice yearly.
- 2) A light film of oil applied to the quill and column will reduce wear, prevent rust, and assure ease of operation.
- 3) Quill return spring should receive oil (SAE 20) once yearly. Remove cover plate and apply oil with squirt can or small brush.
- 4) **IMPORTANT:** The gear box should be oiled with a lubricant such as SAE 68 oil in level. CHANGE OIL EVERY ONE YEAR.

CHANGE THE GEAR BOX OIL: Tilt the head stock over as shown in Fig 2. Open the oil drain plug to allow the oil to drain from the opening completely. Then lock the oil drain plug and turn the head to be upright position. Remove the oil filler plug fill the oil to the gear box until the oil lever reach the middle of oil fluid lever indicator. Then lock the plug.

- 5) Apply Lubriplate to quill pinion every 90 days.

Note: use extreme care when performing this operation and keep hands clear of pinch points. When using paraffin bar, do this only by turning the sheaves by hand. Do not apply with motor running.

USE OF MAIN MACHINE PARTS

- 1) To raise and lower the head by head handle.
- 2) Equipped with an electric switch for tapping operation clockwise or counterclockwise.
- 3) To adjust the quick or slow feeding by feed handle.
- 4) To adjust the table left and right travel by table handle wheel
- 5) To adjust the table fore and aft travel by table handle wheel.
- 6) To operate the spindle handle wheel for micro feed.
- 7) To adjust the scale size according to working need.

Speed changing

FOR SCREW PULLEY speed changing and adjust belt step see Fig. 2

- (1) Turn power off.
- (2) Open belt cover by releasing side latches step see (a), (b), (c)
- (3) Loosen motor mount leaf screw.
- (4) Push motor in order to loosen belts (head side of motor mount is set fixed, two motor's ear side with motor screw to tighten or loosen of belts.)
- (5) Loosen two screws of base for speed change inter pulley that also adjust the location of base for speed change inter pulley.
- (6) Select the suitable r/min from speed charts of Fig.3. Then place the belts on the desired pulley steps.
- (7) Tighten two screws of base for speed change pulley and the bolt of motor mount lock.
- (8) Cover the belt cover with counter step (2) after turn power on;

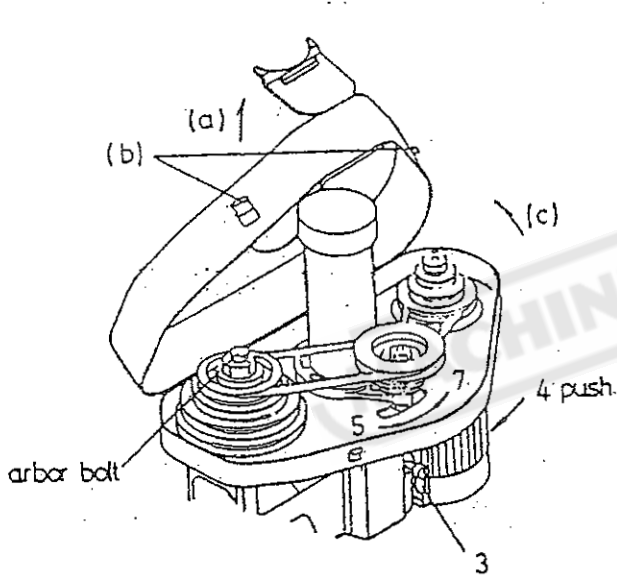
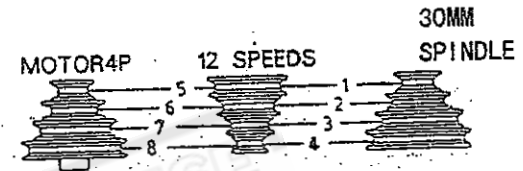

Fig.2



12 SPEEDS		BELT	12 SPEEDS		BELT
50Hz	60Hz		50Hz	60Hz	
100	120	4-5	660	790	1-6
160	195	3-5	885	1065	2-7
190	230	4-6	1020	1220	3-8
240	285	2-5	1260	1515	1-7
310	375	3-6	1510	1810	2-8
365	440	4-7	2150	2580	1-8

Fig.3

FOR GEARED HEAD speed changing

The main driving route of the machine is as follows: motor ---three groups of gears---splined sleeve ---spindle , when using a motor with a 1400r/min as power, 6 spindle speeds from 95 r/min to 1600 r/min can be obtained by shifting the position of sliding gears. If it is needed to change the spindle speed. **Please turn off the power at first.** then turn the changing -speed handle to the required position.

Note: Before changing the speed, the power must be turned off at first.

r/min	L1	L2	L3	H1	H2	H3
5CHz	95	170	280	540	960	1600
6CHz	120	210	345	670	1180	1970

PRECAUTION FOR OPERATION

Check all parts for proper condition before operating. If normal safety precautions are noticed carefully, this machine can provide you with standing of accurate service.

1) Before operation

- a) Fill the lubricant.
- b) In order to keep the accurate precision, the table must be free from dust and oil deposits.
- c) Check to see that the tools are correctly set and the workpiece is set firmly.
- d) Be sure the speed is not set too fast.
- e) Be sure everything is ready before use.

2) After operation

- a) Turn off the electric switch.
- b) Turn down the tools.
- c) Clean the machine and coat it with lubricant.
- d) Cover the machine with cloth to keep out the dust.

3) Adjustment of head

- a) To raise and lower the head, loosen the two heavy duty head lock nuts shown in Fig.1. Use the left side head handle to raise and lower the head on its rack and pinion mechanism. When the desired height is reached, tighten the bolts to avoid vibration.
- b) Head may be rotated 360° by loosening the same bolts mentioned above. Adjust the head to the desired angle, then fix the heavy duty head locknuts. It is tighten the same time to fix the head if drilling & milling too much.
- c) Unscrew 3 nuts while the workpiece needs to be bevel drilled. Turn to the degrees you wish on the scale, then screw the 3.

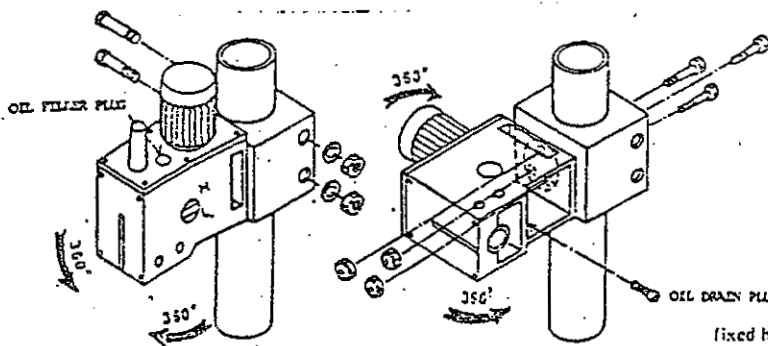

Fig.4

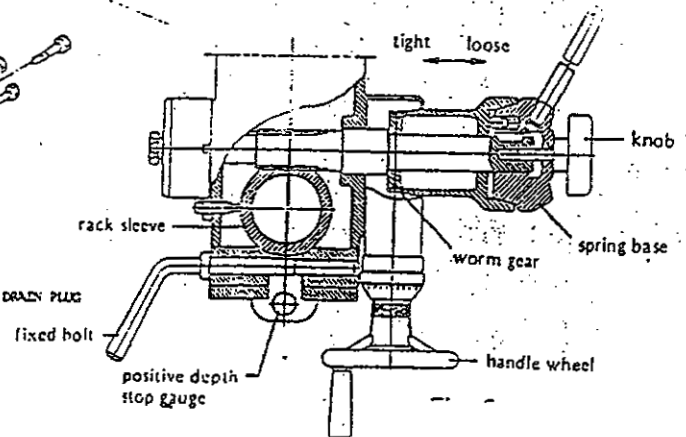

Fig.5

4) Preparing for drilling (see Fig.5).

Turn off the knob make loose the taper body of worm gear and spring base. Then we decide spindle stroke setting the positive depth stop gauge for drilling blind hole or free state for pass hole.

5) Preparing for milling (see Fig.5).

- a) Adjust the positive depth stop gauge to highest point position.

b) Turn tight of the knob be use to taper friction force coupling the worm gear and spring base. Then turning the handle wheel by micro set the spindle of workpiece machining height.

c) Lock the rack sleeve at the desired height with fixed bolt.

Quill return spring adjustment:

Spring tension for return of spindle, after hole drilling, has been pre-set at the factory. No further adjustment should be attempted unless absolutely necessary. Adjustment will probably be required if a multiple spindle drilling or tapping head is used. If adjustment is necessary, loosen lock screw while holding quill spring housing. Do not allow the housing to turn in your hand, or spring will unwind. Turn entire housing assembly clockwise the number of turns necessary to cause the quill to return to its up position. (Note: The flat of the spring housing pilot is lined up with the spring loading hole on the body of the spring housing.) Reset lockscrew make sure point of screw mates to flat on the housing journal.

Adjusting table slack and compensate for wear (see Fig.6)

(ONLY for cross table)

- 1) Your machine is equipped with jib strip adjustment to compensate for wear and excess slack on cross and longitudinal travel.
- 2) Clockwise rotation the job strip bolt with a big screw for excess slack otherwise a little counter clockwise if too tight.
- 3) Adjust the jib strip bolt until feel a slight drag when shifting the table.

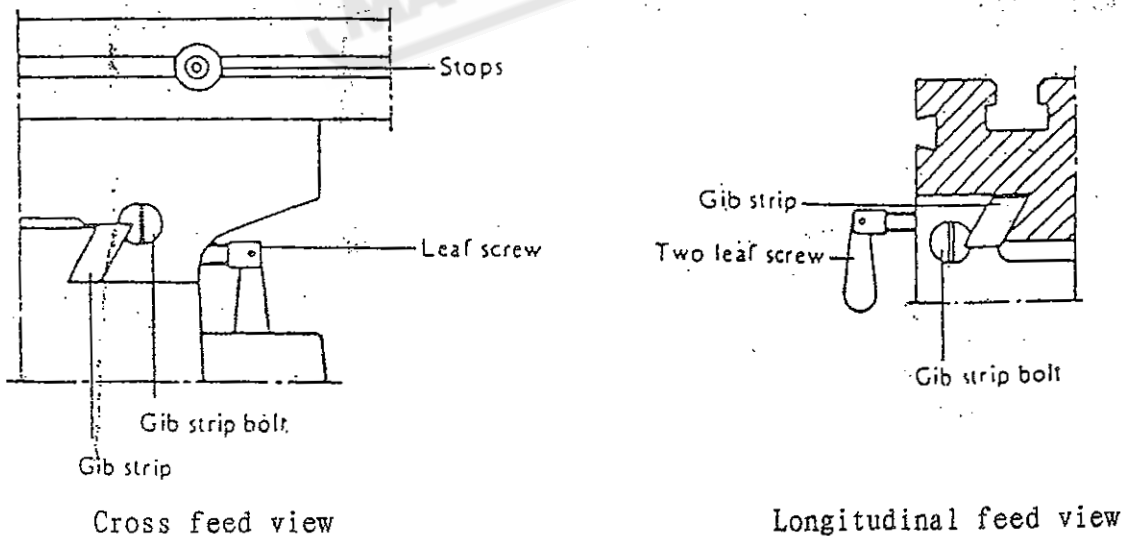

Fig.6

Clamping, table base, and machine base (see Fig.6)

(only for cross table)

- 1) When milling longitudinal feed, it is advisable to lock the cross feed table travel to insure the accuracy of your work. To do this, tighten the small leaf screw on the right side of the table base.

- 2) To lighten the longitudinal feed travel of the table for cross feed milling, tighten the two small leaf screw on the front of the table base.
- 3) Adjustable travel stops are provided on the front of the table for control of cross travel and the desired milling length.

To change tool

- 1) Removing face mill or drill chuck arbor.
Loosen the arbor bolt at the top of the spindle shaft approximately 2 turns with a wrench. Rap the top of the arbor bolt with a mallet.
After taper has been broken loose, holding chuck arbor on hand and turn detach the arbor bolt with the other hand.
- 2) To install face mill or cutter arbor.
Insert cutter and cutter arbor into the taper of spindle. Tighten arbor bolt detach securely, but do not over-tighten.
- 3) Removing taper drills.
 - a) Turn down the arbor bolt insert the taper drill into the spindle shaft.
 - b) Turn the rapid down handle rod down until the oblong hole in the rack sleeve appears. Line up this hole with the hole in the spindle. Insert key punch key through holes and strike lightly with a mallet. This will force the taper drill out.

Electric system

The electric system of this machine can executive drilling and milling operation. Drilling and milling are controlled by a knob, a red mushroom head button the switch box.

1. Main power, switch and attentions

- a. Before using the machine, the circuit breaker and the outlet shall be fixed on the entrance of the power according to the electric skeleton diagram.
- b. Before operating the machine, it should be safely on earth connection. All the working parts must be carefully checked whether they are their original positions.
- c. This machine has a protection switch of belt cover and milling and peeling cover. When opened, the electric circuit of the machine will be shut off forcedly and the machine stops working. So the cover must be closed while the machine still working.
- d. When operating, the red mushroom end should be push upward in accordance with the direction of the arrow. Open the cover and turn to 90degree.
- e. The green button means start. Push it, then the machine works clockwise. Otherwise, the position of any two phases of the three-phase power should be exchanged.
- f. The red button means stop. The red mushroom end button means emergency stop and all stop. When the emergency happens, the machine can stop completely by pushing the red button.
- g. When the cutter is replaced or any other cutting processing happens, the machine must stop working completely to avoid any unnecessary harm and damage.

2. Drilling stop and tapping (Note: only for tapping)

a. DRILLING:

Turn the switch to the position of "DRILLING", turn the switch to the position of "START",

At emergency, please push the "EMERGENCY STOP" BUTTON.

b. TAPPING:

Turn the switch to the position of "TAPPING" set up the tapping septh stop. turn the switch to the " FORWARD" position.

when the spindle reaches the depth you set up, the microswitch "SQ2" will work and the spindle will reverse. when it reaches the upper microswitch "SQ1", the machine will stop.

At emergency, please push the "EMERGENCY STOP" button and the machine will stop immediatly. Then, loose the "EMERGENCY STOP" button. turn the switch to the "REVERSE" position and the spindle will reverse.

NOTE:

When the upper microswitch "SQ1" is active, the "REVERSE" switch will become a "JOG" switch and you can shift gear with the "JOG" switch.

c. STOP:

Turn the switch to the position of "STOP".

d. COOLANT(ONLY FOR COOLANT)

Turn the switch to the position of right, the coolant working. Turn the switch to the position of left, the coolant stop.

3. Drilling and milling (Note:only for Drilling and milling)

Push the green button. The major axis of the machine start working clockwise. It can drill and mill .Push the red one , and the major axis stops working.

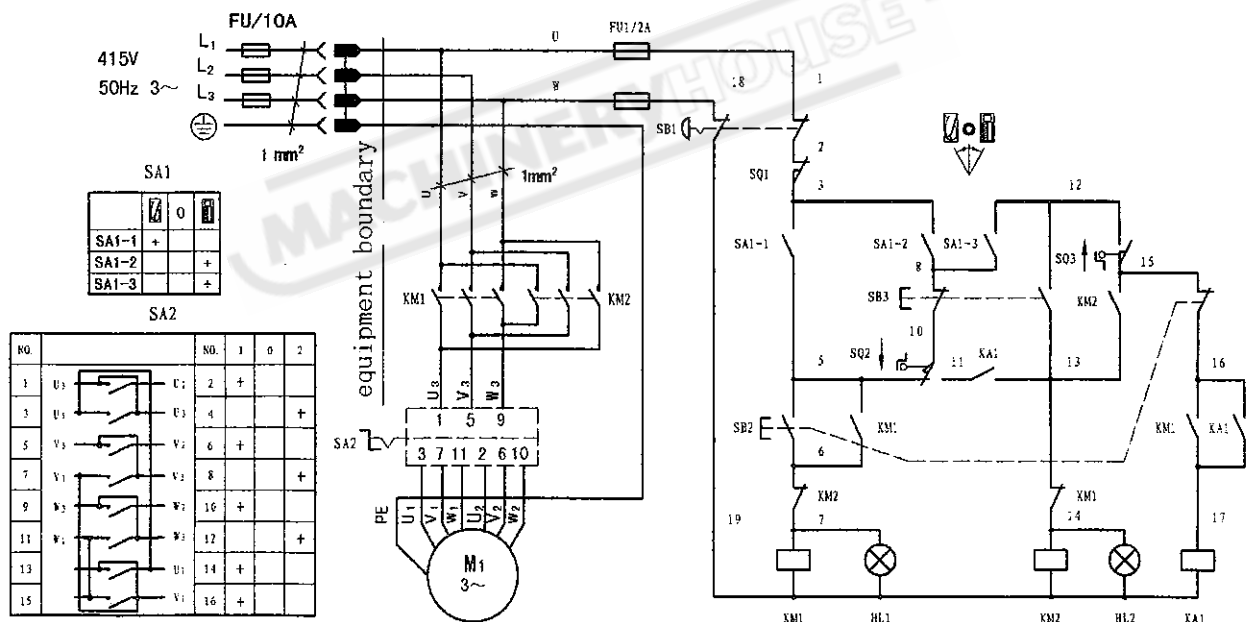

DMF-42 (415V) three-phase control circuit

For step-pulley drive HEAD BODY PARTS (CB)

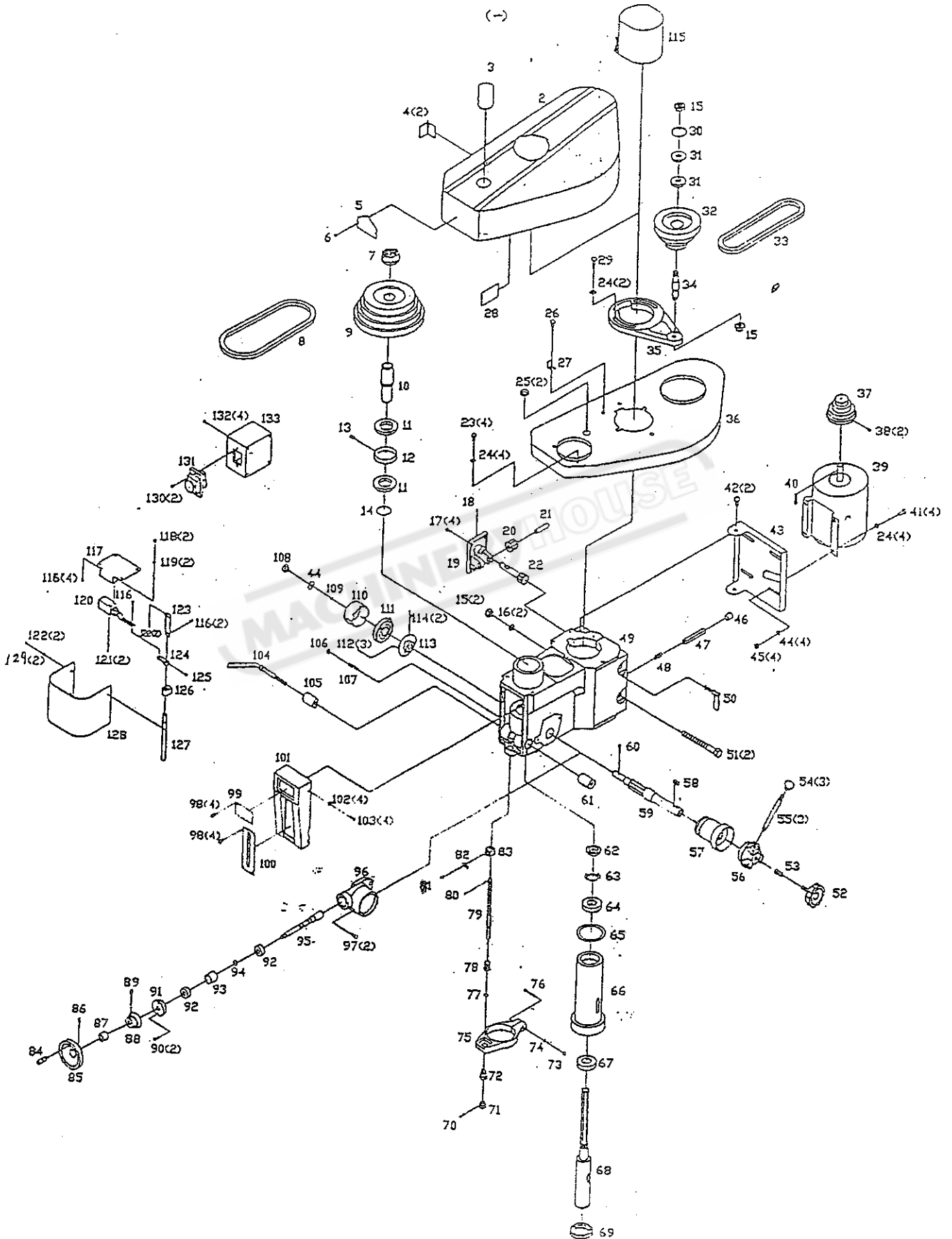

For step-pulley drive

HEAD BODY PARTS (CE)

2	down cover	46	balata jacketing	90	bolt
3	rod	47	tension pin	91	end lid
4	jaw	48	spring cap	92	sealing
5	trademark	49	head body	93	separating ring
6	rivet	50	tight handle	94	retaining ring
7	nut	51	bolt	95	feed worm
8	V-belt	52	big ripple handle	96	feed institution support
9	spindle pulley	53	spring cap	97	bolt
10	spindle pulley	54	handle ball	98	screw
11	splined sleeve	55	handle rod	99	nameplate
12	ball bearing	56	handle body	100	scale
13	screw	57	turbine	101	front cover board
14	retaining ring	58	key	102	washer
15	nut	59	gear shaft	103	screw
16	washer	60	screw	104	handle rod
17	screw	61	fixed collar (thread)	105	fixed tight collar
18	oil cup	62	nut	106	nut
19	bracket	63	washer	107	screw
20	gear	64	ball bearing	108	small ripple handle
21	shaft	65	retaining	109	washer
22	worm	66	sleeve	110	spring cap
23	bolt	67	ball bearing	111	spring plate
24	washer	68	spindle	112	screw
25	separating ring	69	ball bearing lid	113	shaft sleeve
26	screw	70	pin	114	pin
27	wire californium	71	knob	115	small cover
28	warning board	72	locating sleeve	116	screw
29	bolt	73	nut	117	safe switch rack
30	retaining ring	74	washer	118	screw
31	ball bearing	75	feed support	119	washer
32	middle pulley	76	bolt	120	safe switch
33	V-belt	77	nut	121	screw
34	middle pulley shaft	78	fixed nut	122	screw
35	pulley support	79	adjustable rod	123	fixed board
36	down cover	80	pin	124	connecting rod
37	motor pulley	81	screw	125	screw
38	screw	82	referral -board	126	shaft sleeve
39	motor	83	stop lump	127	shaft
40	key	84	turn handle	128	protect board
41	bolt	85	small handle wheel	129	washer
42	bolt	86	screw	130	screw
43	motor rack	87	adapter sleeve	131	switch
44	washer	88	graduation plate	132	screw
45	nut	89	screw	133	electric box

For step-pulley drive HEAD BODY PARTS (NO CE)

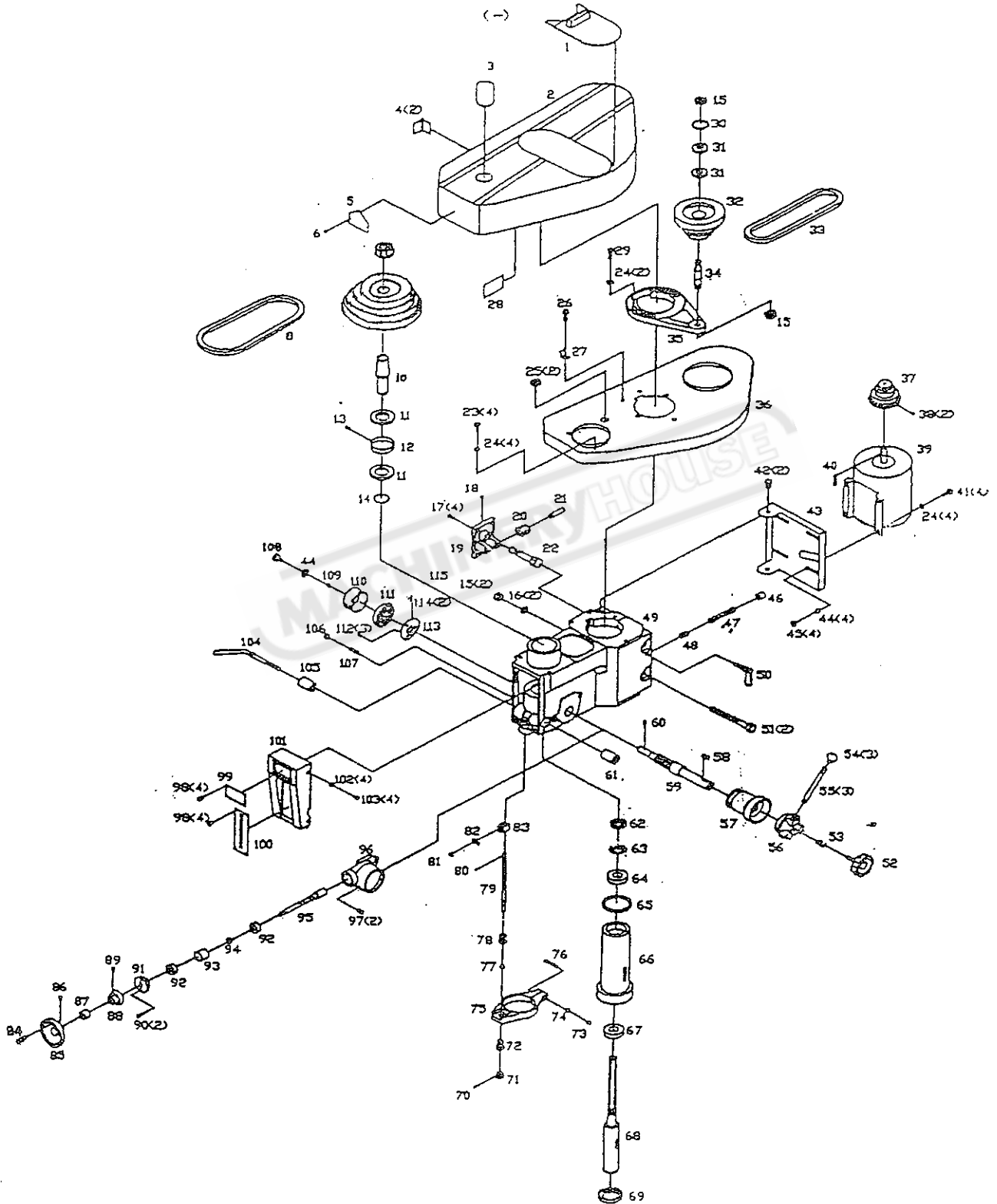

For step-pulley drive

HEAD BODY PARTS (NO CE)

NO	NAME	NO	NAME	NO	NAME
1	cover board	39	motor	77	nut
2	up cover	40	key	78	fixed nut
3	round	41	bolt	79	adjustable rod
4	jaw	42	bolt	80	pin
5	trademark	43	motor rack	81	screw
6	rivet	44	washer	82	referral-board
7	nut	45	nut	83	stop lump
8	V-belt	46	balata jacketing	84	turn handle
9	spindle ring	47	tension pin	85	small hand wheel
10	splined sleeve	48	spring	86	screw
11	ball bearing	49	spindle box	87	adapter sleeve
12	separating ring	50	tight handle	88	graduation plate
13	screw	51	bolt	89	screw
14	retaining ring	52	big ripple handle	90	bolt
15	nut	53	spring	91	end lid
16	washer	54	handle ball	92	ball bearing
17	screw	55	handle rod	93	separating ring
18	oil cup	56	handle body	94	retaining ring
19	bracket	57	turbine	95	feed worm
20	gear	58	key	96	feed institution support
21	shaft	59	gear shaft	97	bolt
22	worm	60	screw	98	screw
23	bolt	61	fixed tight collar (thread)	99	nameplate
24	washer	62	nut	100	scale
25	separating ring	63	washer	101	front cover board
26	screw	64	ball bearing	102	washer
27	wire californium	65	retaining	103	screw
28	warning board	66	sleeve	104	handle rod
29	bolt	67	ball bearing	105	fixed tight collar
30	retaining ring	68	spindle	106	nut
31	ball bearing	69	ball bearing lid	107	screw
32	middle pulley	70	pin	108	small ripple handle
33	V-belt	71	knob	109	washer
34	middle pulley shaft	72	locating sleeve	110	spring cap
35	pulley support	73	nut	111	spring plate
36	down cover	74	washer	112	screw
37	motor pulley	75	feed support	113	shaft sleeve
38	screw	76	bolt	114	pin

For geared head drive

HEAD BODY PARTS

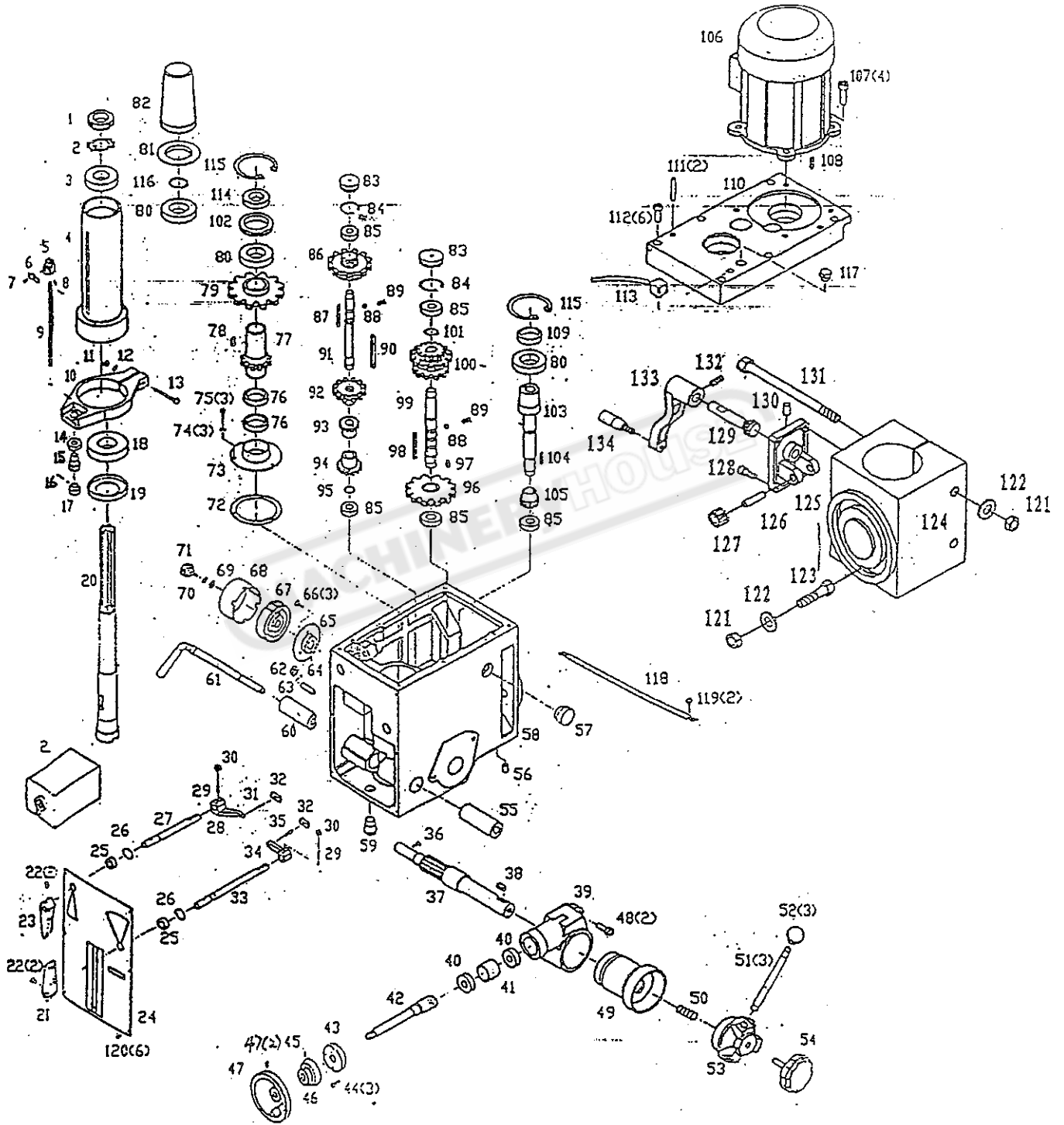

For geared head drive HEAD BODY PARTS

1	lock washer	46	graduation plate	91	key
2	ball bearing	47	handle wheel	92	shaft III
3	washer	47(1)	screw	93	gear
4	sleeve	48	screw	94	gear
5	fixed bolt	49	worm gear	95	retaining ring
6	scale-board	50	spring	96	gear
7	screw	51	handle rod	97	key
8	pin	52	handle ball	98	key
9	graduated rod	53	handle body	99	shaft II
10	feed base	54	big ripple handle	100	gear
11	nut	55	fixed tight collar	101	retaining ring
12	washer	56	oil cover	102	separating ring
13	screw	57	oil pointer	103	motor shaft
14	nut	58	head body	104	key
15	support	59	fixed nut	105	gear
16	pin	60	fixed tight collar	106	motor
17	knob	61	handle rod	107	screw
18	ball bearing	62	nut	108	key
19	bearing cup	63	screw	109	oil seal
20	spindle	64	pin	110	head body cover
21	electric box	65	spring base	111	pin
22	screw	66	washer	112	screw
23	speed lever	67	spring plate	113	pipe radiator
24	name plate	68	spring cap	114	oil seal
25	oil seal	69	washer	115	retaining ring
26	retaining ring	70	washer	116	retaining ring
27	lever shaft(left)	71	small ripple handle	117	oil cup
28	lever(left)	72	airtight ring	118	degree-meter
29	screw	73	airtight base	119	screw
30	nut	74	washer	120	screw
31	pin	75	screw	121	nut
32	lever bracket	76	oil seal	122	washer
33	lever shaft(right)	77	gear	123	bolt
34	lever(right)	78	key	124	support
35	pin	79	gear	125	bracket
36	screw	80	ball bearing	126	pin
37	pinion shaft	81	arbor bolt cover base	127	worm gear
38	key	82	arbor bolt cover	128	screw
39	feed cover	83	cap	129	worm shaft
40	ball bearing	84	retaining ring	130	oil cup
41	separating ring	85	ball bearing	131	bolt
42	worm shaft	86	gear	132	screw
43	worm cover	87	key	133	handle of worker table
44	screw	88	steel ball	134	roll handle
45	screw	89	spring		

TABLE, BASE AND COLUMN PARTS (NO COOLANT)

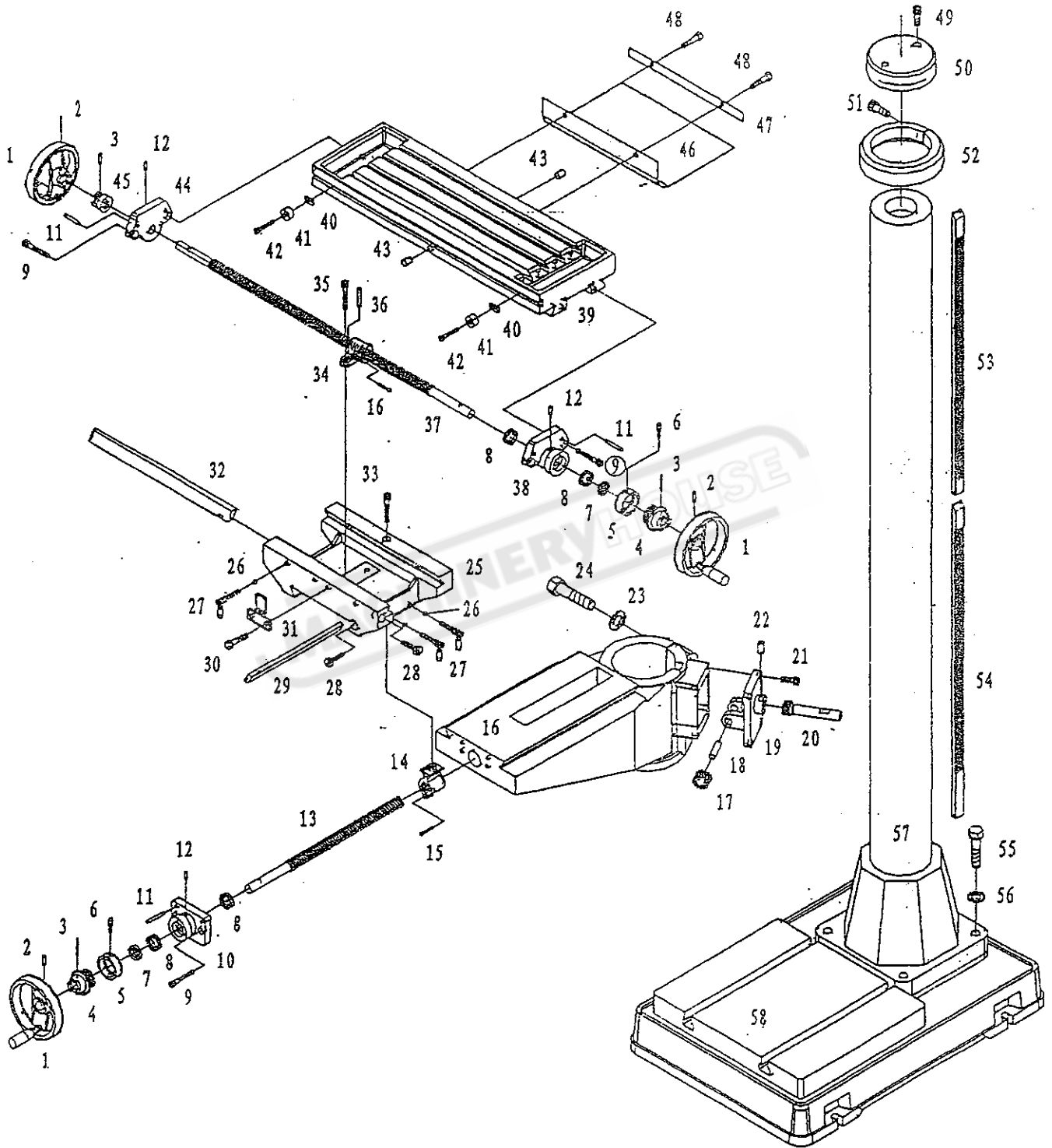

TABLE, COLUMN AND BASE PARTS (NO COOLANT)

NO.	NAME	NO.	NAME
1	feed handle	30	bolt
2	screw	31	limited board
3	pin	32	long gib strip
4	scale base	33	screw
5	graduation plate	34	long guide screw nut
6	screw	35	screw
7	adjust washer	36	pin
8	ball bearing	37	long guide screw
9	screw	38	right guide screw support
10	short guide screw support	39	table
11	pin	40	ladder-shaped nut
12	oil cup	41	limited board
13	short guide screw	42	screw
14	short guide screw nut	43	oil cup
15	screw	44	left guide screw support
16	brace	45	dial clutch
17	gradient gear	46	protect board
18	pin	47	protect board slice
19	elevoting support	48	bolt
20	elevoting worm	49	screw
21	screw	50	column lid
22	oil cup	51	bolt
23	washer	52	link
24	bolt	53	rock (for head body)
25	table	54	riock (for table)
26	steel ball	55	bolt
27	lock screw	56	washer
28	gib strip screw	57	column
29	short gib strip	58	base

COLUMN AND BASE PARTS (COOLANT)

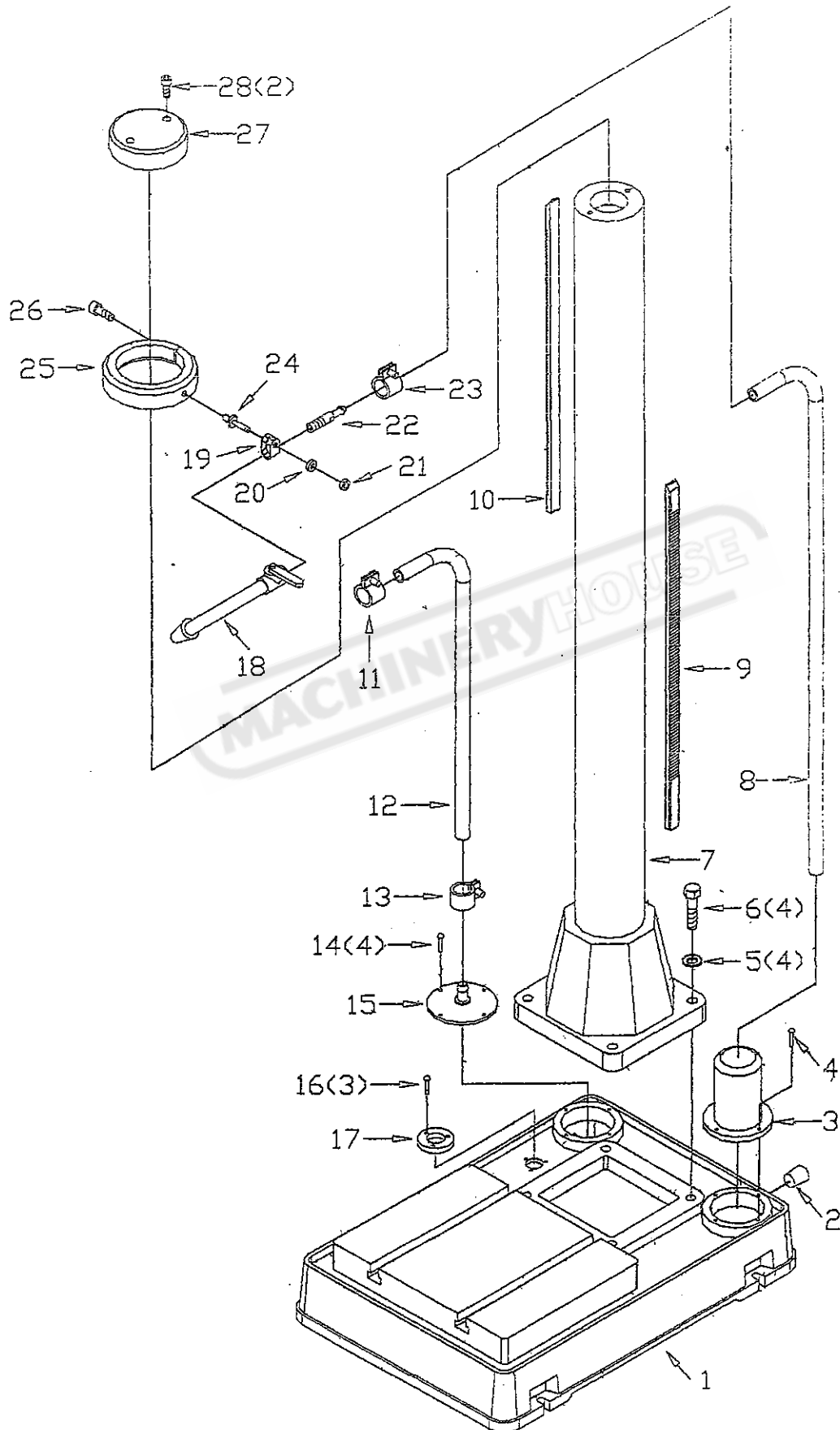
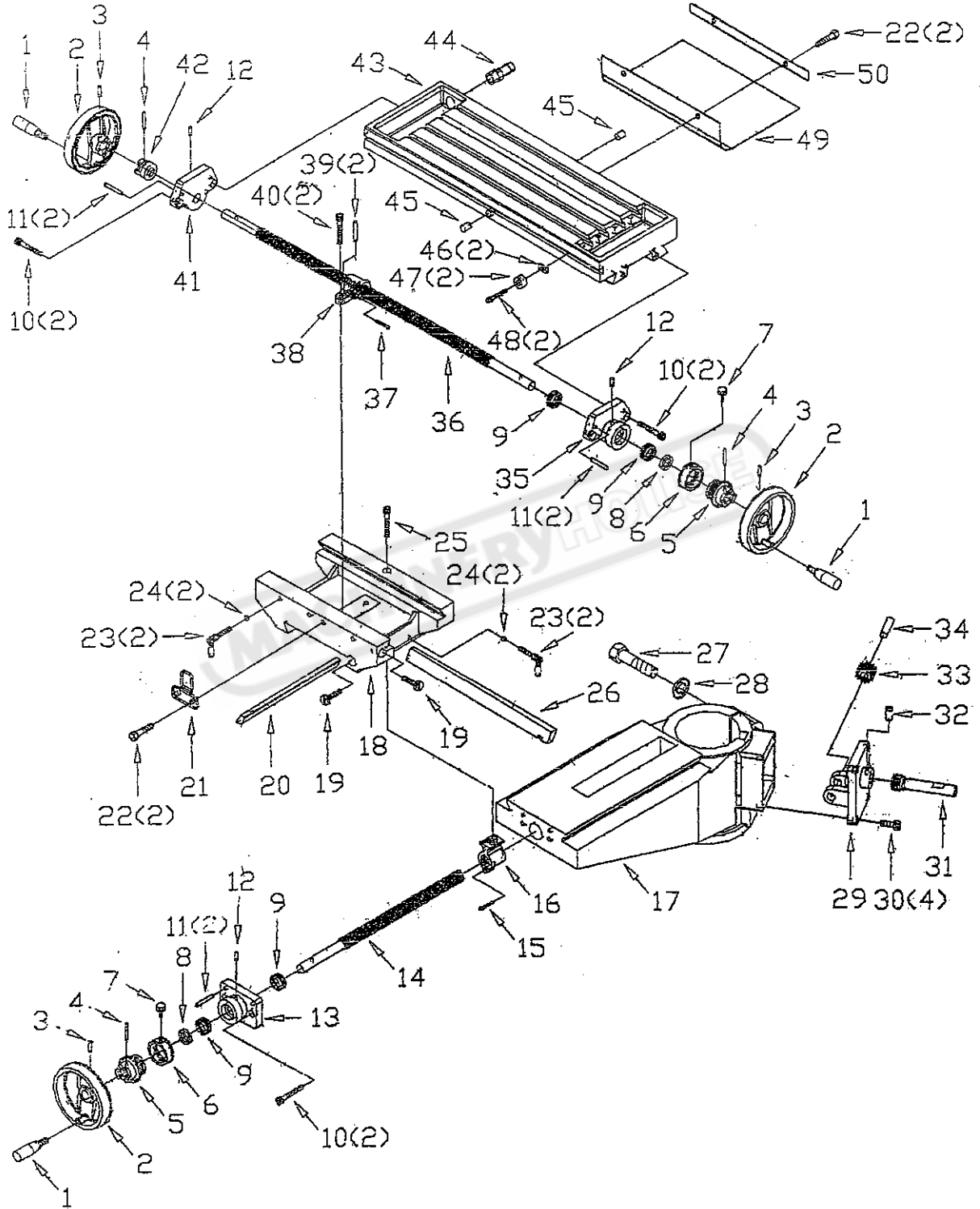

TABLE PARTS (COOLANT)



COLUMN AND BASE PARTS (COOLANT)

NO.	NAME	NO.	NAME
1	base	15	finger plate
2	oil stopper	16	screw
3	coolant pump	17	filter
4	screw	18	nozzle
5	washer	19	spring holder
6	bolt	20	washer
7	column	21	nut
8	coolant pipe	22	joint
9	rack of table arm	23	holder of flexible hose
10	rack of headstock	24	double head screw
11	holder of coolant pipe	25	column ring
12	flexible hose	26	screw
13	holder of coolant pipe	27	column cover
14	screw	28	screw

TABLE PARTS (COOLANT)

NO.	NAME	NO.	NAME
1	handle	26	long gib strip
2	wheel	27	bolt
3	screw	28	washer
4	pin	29	elevoting support
5	scale base	30	screw
6	graduation plate	31	elevoting worm
7	screw	32	oil cup
8	adjust washer	33	gradient gear
9	ball bearing	34	pin
10	screw	35	right guide screw support
11	pin	36	long guide screw
12	oil cup	37	screw
13	short guide screw support	38	long guide screw nut
14	short guide screw	39	pin
15	screw	40	screw
16	short guide screw nut	41	left guide screw support
17	brace	42	dial clutch
18	table	43	table
19	gib strip screw	44	joint of flexible hose
20	short gib strip	45	oil cup
21	limited board	46	ladder-shaped nut
22	bolt	47	limited board
23	lock screw	48	screw
24	steel ball	49	protect board
25	screw	50	protect board slice

TABLE. BASE AND COLUMN PARTS (NO COOLANT)

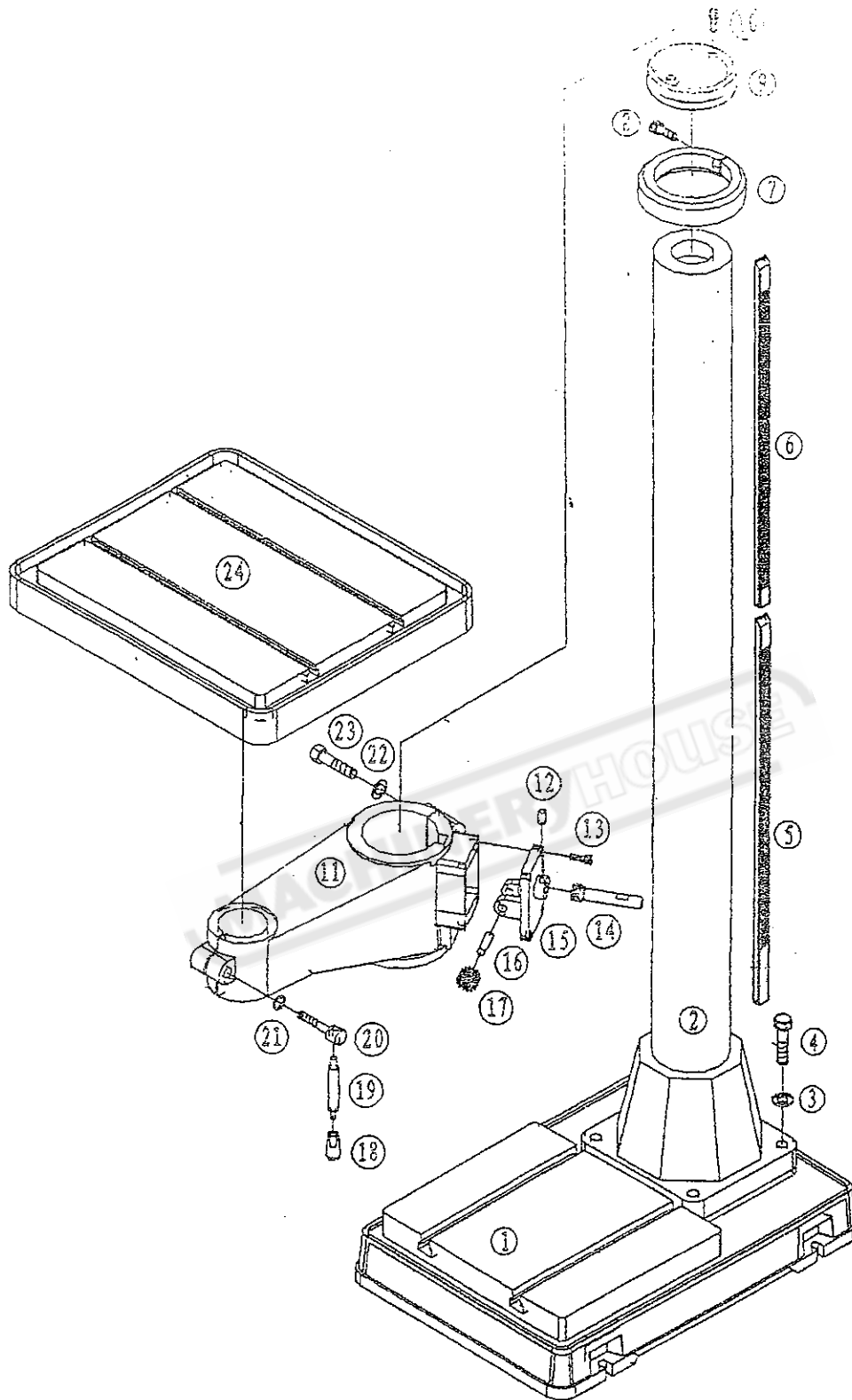

1	base	9	column lid	17	worm gear
2	column	10	screw	18	handle knob
3	washer	11	shift table	19	handle rod
4	bolt	12	oil cup	20	bolt
5	rock (for table)	13	screw	21	washer
6	rock (for head body)	14	worm shaft	22	washer
7	link	15	bracket	23	bolt
8	bolt	16	pin	24	table

TABLE, COLUMN AND BASE PARTS (COOLANT)

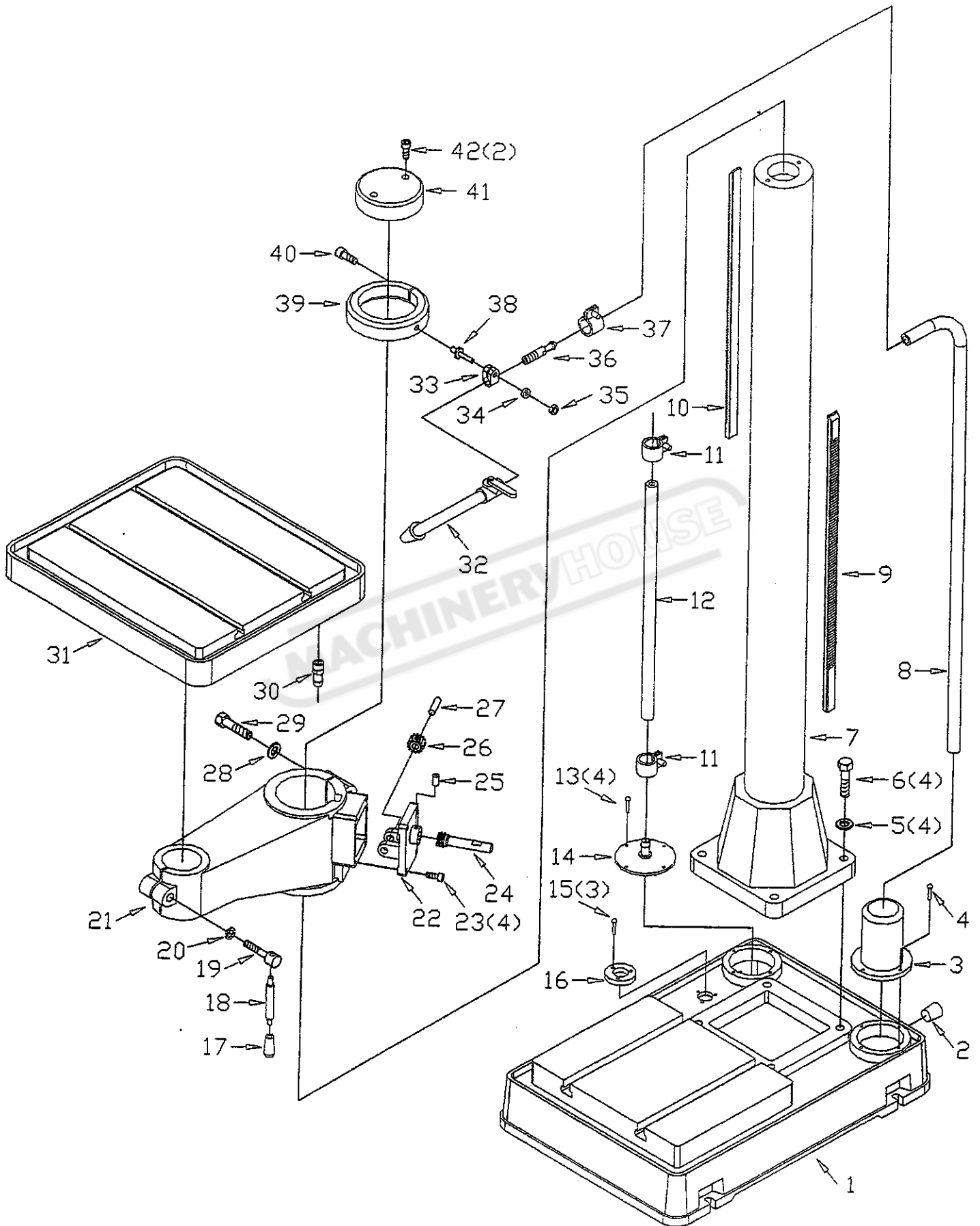

TABLE, BASE AND COLUMN PARTS (COOLANT)

NO.	NAME	NO.	NAME
1	base	23	screw
2	oil stopper	24	worm shaft
3	coolant pump	25	oil cup
4	screw	26	worm gear
5	washer	27	pin
6	bolt	28	washer
7	column	29	bolt
8	coolant pipe	30	joint
9	rack of table arm	31	table
10	rack of headstock	32	nozzle
11	holder of coolant pipe	33	spring holder
12	flexible hose	34	washer
13	screw	35	nut
14	flange joint	36	joint
15	screw	37	holder of coolant pipe
16	filter	38	double head screw
17	handle knob	39	column ring
18	handle rod	40	screw
19	bolt	41	column cover
20	washer	42	screw
21	shift table		
22	bracket		